

**A rugged, long-life workhorse control valve that takes punishment in stride.**

### Features

- Rotary-valve design provides shearing action between the V-notch ball and the seat, promoting a smooth, non-clogging operation
- Straight-through flow design provides high capacity for fibrous slurries, steam, liquids and gases
- With a single-seat design, torque is lower than typical trunnion design valves, for ease of operation and reduced actuator cost
- Two seat designs:
  - Laminated seat provides tight shut-off and withstands tough operating conditions
  - Thick (solid) seat for high-velocity and abrasive or erosive service
- Segmented, V-notched ball features high rangeability and smooth throttling action
- Choice of full and reduced port, providing the right flow capacity for every application at low cost
- Heavy-duty, stainless steel stem for high strength and rigidity
- Multiple, adjustable ring packing allows easy adjustment without requiring valve disassembly or actuator removal
- Stem bearings assure lasting, smooth and easy valve operation
- ASME Class 150 and 300 bodies, both available in stainless or carbon steel
- Positive alignment of split body

### General applications

- Critical services in pulp and paper industry
- Fibrous materials, pellet state slurry, high viscous solutions and other fluids having special characteristics

### Special tests

- Liquid penetrant
- Magnetic-particle
- Ultra-sonic
- X-ray



### Technical data

Models /Sizes	: W0601, W0602 Full bore 25mm to 300mm (1" to 12") : W0401, W0402 Reduced bore 40mm to 500mm (1½" to 20")
Pressure rating	: ASME Class 150, 300
End connection	: ASME Class 150, 300 raised face flange
Face to face	: Reduced bore ASME B16.10 (short pattern) : Full bore ASME B16.10 (long pattern)
Temperature	: -29°C to 350°C
Seat leakage	: FCI 70-2 : Class IV (Laminated seat) : Class II (Thick seat)

# KTM V-Port Control Ball Valves

Full bore and Reduced bore

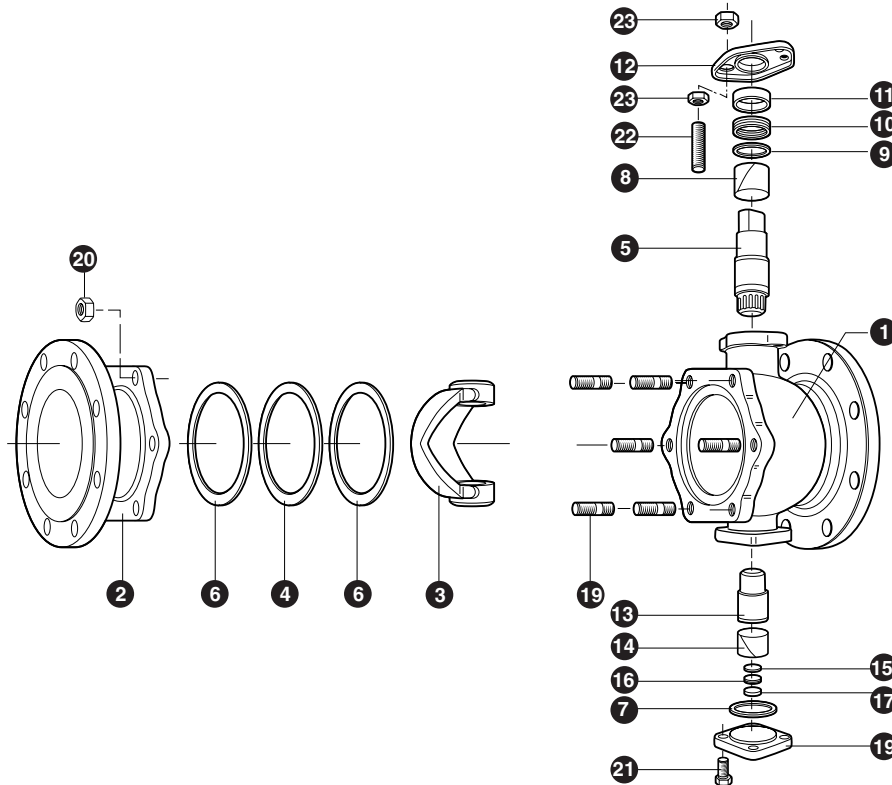

This illustration shows body construction of V-port ball valve Model W0401 series in size 100mm. Construction of other sizes differs slightly.

1. Stem and disc are connected by spline in Model W0401 size 40mm to 350mm and in Model W0601 size 25mm to 300mm. Connections in larger sizes are by key.
2. A throttle lever, not shown here, is required for manual operation.

## Parts List and Materials of Construction

No.	Parts Name	Material	Qty
1	Body	Carbon Steel or 316SS	1
2	Body Cap	Carbon Steel or 316SS	1
3	Disc	316SS Hard Chrome or 316SS Stellite	1
4	Seat	Laminated 316SS or Thick (solid) 316SS Stellite	1
5	Stem	316 SS	1
6	Gasket	RPTFE or Non Asbestos Joint Sheet	1
7	Gasket	RPTFE or Non Asbestos Joint Sheet	1
8	Stem Bearing	RPTFE	1
9	Thrust Washer	316SS	1
10	Gland Packing	Standard PTFE V-Ring or Optional Expanded Graphite	1 set
11	Gland	304SS	1
12	Gland Flange	304SS	1
13	Lower Stem	316SS	1
14	Stem Bearing	RPTFE	1
15	Thrust Bearing	RPTFE	1
16	Shim	316SS	0-4
17	Pivot	316SS	1
18	Lower Cover	Carbon Steel or 316SS	1
19	Stud	A193 Gr.B7 or A193 Gr.B8	6
20	Nut	A194 Gr.2H or A194 Gr.8	6
21	Bolt	A354 Gr.BC or A193 Gr.B8	4
22	Gland Bolt	304SS	2
23	Nut	304SS	4

## Seat Selection

The KTM Single V is a single-seat design. Torque is lower than typical trunnion design valves resulting in easier operation and reduced actuator cost. Choose from two unique seat designs:

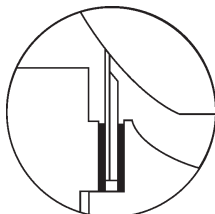

**Laminated Seat**

Provides tight shut-off and withstands tough operating conditions.  
FCI 70-2 Class IV shut-off.

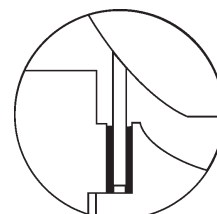

**Thick (Solid) Seat**

For high-velocity and abrasive or erosive service.  
FCI 70-2 Class II shut-off.

## Inherent Flow Characteristics

Single-V valves maintain an inherent flow characteristic, which is approximately midway between linear and equal percent.

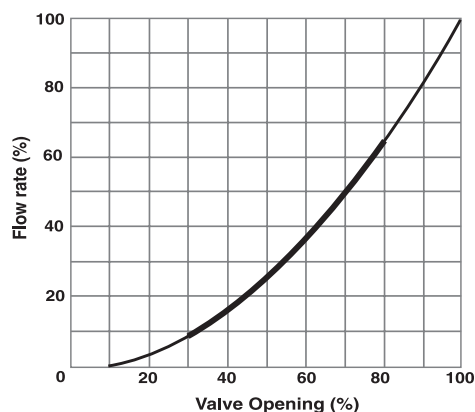

## Materials Selection

Temperature	Gland packing	Thrust bearing	Stem bearing	Seat
up to 200°C	PTFE	316SS / Reinforced PTFE	Reinforced PTFE	Laminated / Thick Seat
200 to 250°C	Reinforced PTFE			
>250°C	Graphite	316SS	Stellite	

\* Laminated Seat (Max. temp 300°C), Thick Seat (Max. temp 350°)

## Test Pressure

ASME Class	Body (MPa)	Seat (MPa)
150	2.93	Mop ( * ) x 1.1 or 0.5 MPa unless otherwise stated
300	7.58	

( \* ) MOP: Max. Operating Pressure

# KTM V-Port Control Ball Valves

Full bore and Reduced bore

## Maximum Allowable Shut off Pressure

Valve Size (mm)		Max. Shut-off Pressure (MPa)	
W0600 series Full-Bore	W0400 series Reduced-Bore	Laminated Seat	Thick Seat
25	40	2.2	5
40	50	2.2	5
50	65	2.2	5
65	80	2.2	5
80	100	2.1	5
100	125	2.0	5
125	150	1.9	5
150	200	1.7	5
200	250	1.5	2
250	300	1.3	2
300	350	1.2	2
-	400	1.0	2
-	450	0.8	2
-	500	0.6	2

## Valve opening vs. Flow Coefficient Cv (Pipe size is same as valve size)

### Laminated Seat

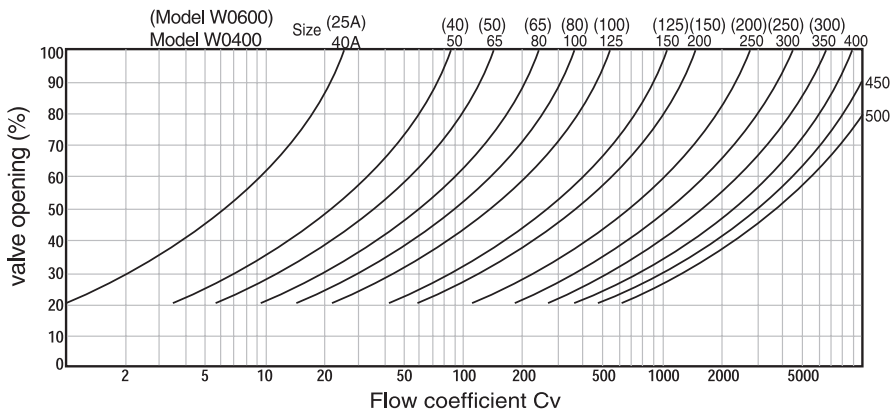

### Thick Seat

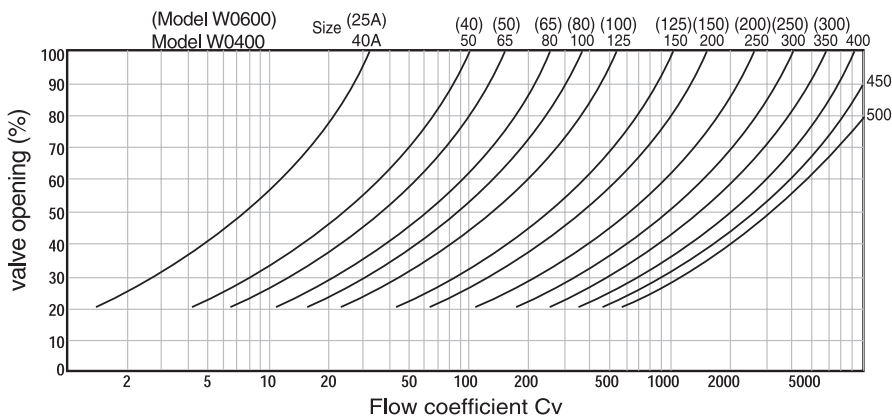

**Model W0600 (Full bore)**

Nominal Size (mm)	Effective Flow Coefficient Cv					
	Valve Size = Pipe Size		Valve Size = 2/3 Pipe Size		Valve Size = 1/2 Pipe Size	
	Thick Seat	Laminated Seat	Thick Seat	Laminated Seat	Thick Seat	Laminated Seat
25	33	25	26	22	23	20
40	105	90	72	66	60	57
50	160	145	118	112	101	97
65	270	245	190	180	160	155
80	390	360	280	270	235	230
100	580	550	450	430	387	378
125	1,130	1,070	790	770	660	650
150	1,650	1,500	1,140	1,090	950	920
200	2,850	2,750	2,000	1,960	1,680	1,660
250	4,500	4,400	3,140	3,110	2,630	2,610
300	6,600	6,450	4,560	4,510	3,820	3,790

**Model W0400 (Reduced bore)**

Nominal Size (mm)	Effective Flow Coefficient Cv					
	Valve Size = Pipe Size		Valve Size = 2/3 Pipe Size		Valve Size = 1/2 Pipe Size	
	Thick Seat	Laminated Seat	Thick Seat	Laminated Seat	Thick Seat	Laminated Seat
40	33	25	31	24	30	24
50	105	90	90	80	82	74
65	160	145	140	130	130	120
80	270	245	220	210	200	190
100	390	360	340	320	310	300
125	580	550	510	490	470	460
150	1,130	1,070	920	890	810	790
200	1,650	1,500	1,420	1,320	1,290	1,220
250	2,850	2,750	2,390	2,330	2,140	2,100
300	4,500	4,400	3,660	3,610	3,240	3,210
350	6,600	6,450	5,230	5,140	4,580	4,530
400	9,250	9,000	7,140	7,020	6,180	6,110
450	12,300	12,000	9,300	9,170	8,000	7,910
500	15,500	15,200	11,610	11,490	9,960	9,880

**Sizing Equation**

Fluid	Remarks	Equation	Nomenclature
Liquid	$\Delta P < F_L^2 (P_1 - P_v)$	$F_p \cdot Cv = \frac{Q}{0.0865} \sqrt{\frac{G}{\Delta P}}$	Cv : Flow coefficient F <sub>k</sub> : Specific heat ratio factor F <sub>p</sub> : Piping geometry factor F <sub>L</sub> : Liquid pressure recovery factor of a control valve without attached fittings G : Relative density for liquid G <sub>g</sub> : Relative density for gas P <sub>1</sub> : Inlet absolute pressure P <sub>2</sub> : Outlet absolute pressure <sup>v</sup> ΔP : Differential pressure P <sub>v</sub> : Vapour pressure of liquid Q : Volumetric flow rate T <sub>1</sub> : Inlet absolute temperature T <sub>sh</sub> : Degree of superheat Y : Expansion factor Z : Compressibility factor : Density of fluid at T <sub>1</sub> X : Ratio of pressure differential to inlet absolute pressure X <sub>T</sub> : Pressure differential ratio factor of a control valve without attached fittings at choked flow X <sub>TP</sub> : Pressure differential ratio factor of a control valve without attached fittings at choked flow W : Mass flow rate
	$\Delta P \geq F_L^2 (P_1 - P_v)$	$F_p \cdot Cv = \frac{Q}{0.0865 \cdot F_L} \sqrt{\frac{G}{P_1 - P_v}}$	
Gas	$X < F_k \cdot X_T$	$F_p \cdot Cv = \frac{Q}{41.31 \cdot P_1 \cdot Y} \sqrt{\frac{G_g \cdot T_1 \cdot Z}{X}}$	
	$X \geq F_k \cdot X_T$	$F_p \cdot Cv = \frac{W}{2.73 \cdot Y \cdot \sqrt{X \cdot P_1 \cdot \gamma_1}}$ $F_p \cdot Cv = \frac{Q}{41.31 \cdot 0.667 \cdot P_1} \sqrt{\frac{G_g \cdot T_1 \cdot Z}{F_k \cdot X_T}}$ $F_p \cdot Cv = \frac{W}{2.73 \cdot 0.667 \cdot \sqrt{F_k \cdot X_T \cdot P_1 \cdot \gamma_1}}$	
Steam	$\Delta P < F_L^2 \cdot (P_1/2)$	$Cv = \frac{W}{0.136 \sqrt{\Delta P (P_1 + P_2)}}$	
	$\Delta P \geq F_L^2 \cdot (P_1/2)$	$Cv = \frac{W}{0.118 \cdot F_L \cdot P_1}$	
Steam Super heated	$\Delta P < F_L^2 \cdot (P_1/2)$ $\Delta P \geq F_L^2 \cdot (P_1/2)$	$Cv = \frac{W(1+0.00126 \cdot T_{sh})}{0.136 \sqrt{\Delta P (P_1 + P_2)}}$ $Cv = \frac{W(1+0.00126 \cdot T_{sh})}{0.118 \cdot F_L \cdot P_1}$	

# KTM V-Port Control Ball Valves

Full bore and Reduced bore

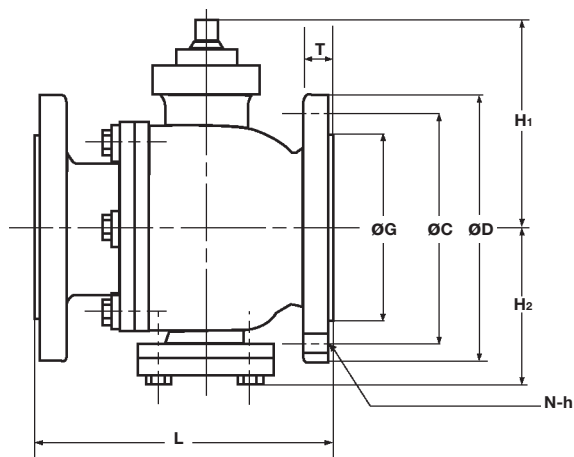

D : Outside diameter  
 C : Bolt circle diameter  
 G : Raised face diameter  
 T : Flange thickness  
 N : Number of bolts  
 h : Bolt hole size

## ASME Class 150 Dimensions (mm)

Valve Size (mm)	W0601 Full Bore			W0401 Reduced Bore			Flange Dimensions					
	L	H <sub>1</sub>	H <sub>2</sub>	L	H <sub>1</sub>	H <sub>2</sub>	D	C	G	T	N	h
25	127	88	62	-	-	-	108	79.5	51	11.2	4	16
40	165	118	87	165	88	62	127	98.5	73	14.3	4	16
50	178	123	92	178	118	87	152	120.5	92	15.9	4	19
65	190	157	105	190	123	92	178	139.5	105	17.5	4	19
80	203	163	111	203	157	105	190	152.2	127	19.1	4	19
100	229	184	131	229	163	111	229	190.5	157	23.9	8	19
125	356	250	177	254	184	131	254	216.0	186	23.9	8	22
150	394	263	180	267	250	177	279	241.5	216	25.4	8	22
200	457	336	246	292	263	180	343	298.5	270	28.6	8	22
250	533	361	271	330	336	246	406	362.0	324	30.2	12	25
300	610	453	333	502	361	271	483	432.0	381	31.8	12	25
350	-	-	-	572	453	333	533	476.0	413	35.0	12	29
400	-	-	-	610	478	358	597	539.5	470	36.6	16	29
450	-	-	-	660	538	412	635	578.0	533	39.7	16	32
500	-	-	-	711	580	433	698	635.0	584	42.9	20	32

## ASME Class 300 Dimensions (mm)

Valve Size (mm)	W0602 Full Bore			W0402 Reduced Bore			Flange Dimensions					
	L	H <sub>1</sub>	H <sub>2</sub>	L	H <sub>1</sub>	H <sub>2</sub>	D	C	G	T	N	h
25	165	88	67	-	-	-	124	89.0	51	17.5	4	19
40	190	118	94	190	88	67	156	114.5	73	20.7	4	19
50	216	123	99	216	118	94	165	127.0	92	22.3	8	22
65	241	157	110	241	123	99	190	149.0	105	25.4	8	22
80	283	163	116	283	157	110	210	168.0	127	28.6	8	22
100	305	184	136	305	163	116	254	200.0	157	31.8	8	22
125	381	250	185	381	184	136	279	235.0	186	35.0	8	22
150	403	263	187	403	250	185	318	270.0	216	36.6	12	22
200	502	336	246	419	263	187	381	330.0	270	41.3	12	25
250	568	361	270	457	336	246	444	387.5	324	47.7	16	29

**Pulp consistency correction**

Pulp consistency	Consistency correction factor Ks		Calculation method
	Chemical stock	Mechanical stock	
1	1.00	1.00	$Q^L = KsQ$ Q : Actual flow rate Ks: Correction factor $Q^L$ is calculated from this equation and required Cv is determined by substituting this $Q^L$ in above sizing equation
2	1.03	1.01	
3	1.11	1.05	
4	1.20	1.09	
5	1.25	1.11	

**Trim Table Model W0600 (Full Bore)**

Trim Code	3L		3S	
	25mm to 250mm <sup>*1</sup>	300mm to 450mm	25mm to 250mm <sup>*1</sup>	300mm to 450mm
Disc	SCS14A HCr	SCS13A HCr	SCS14A Stellite	SCS14A Stellite
Stem	SUS316	SUS304	SUS316	SUS304
Seat	Laminate <sup>*2</sup>		SCS316 Stellite	SCS304 Stellite

<sup>\*1</sup> NCB Body / 40mm to 250mm

<sup>\*2</sup> Laminate Seat / 300mm and smaller: SUS316; 350mm and larger: SUS304

HCr: Hard chromium plating

**Trim Table Model W0400 (Reduced Bore)**

Trim Code	3L		3S	
	40mm to 300mm	350mm to 500mm	40mm to 300mm	350mm to 500mm
Disc	SCS14A HCr	SCS13A HCr	SCS14A Stellite	SCS14A Stellite
Stem	SUS316	SUS304	SUS316	SUS304
Seat	Laminate <sup>*3</sup>		SCS316 Stellite	SCS304 Stellite

<sup>\*3</sup> Laminate Seat / 350mm and smaller: SUS316; 400mm and larger: SUS304

HCr: Hard chromium plating

# KTM V-Port Control Ball Valves

Full bore and Reduced bore

## New KTM Model Coding System

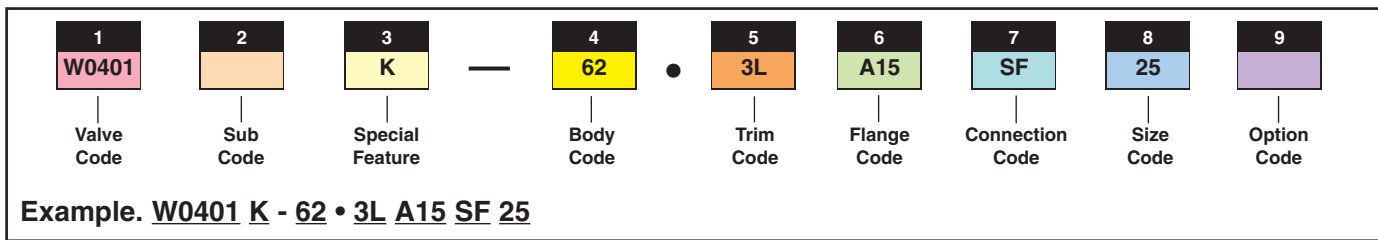

1	Class		Description
Valve Code	JIS	ASME	
W0601	10K	150	Full bore, 25mm to 450mm
W0602	20K	300	Full bore, 25mm to 450mm
W0401	10K	150	Reduce bore, 40mm to 500mm
W0402	20K	300	Reduce bore, 40mm to 500mm

6	Description	
Flange Code	JIS	ASME
J10	JIS 10K	
J20	JIS 20K	
A15		ASME Class 150
A30		ASME Class 300

2	Description
Sub Code	
Blank	Metal Seat

7	Description
Connection Code	
Blank	Raised Face
SF	Smooth Finish 125 to 250 AARH

3	Description
Special Features	
Blank	Not applicable
K	Powder Service

8	mm	inch
Size Code		
25	25	1
32	32	1 <sup>1</sup> / <sub>4</sub>
40	40	1 <sup>1</sup> / <sub>2</sub>
50	50	2
65	65	2 <sup>1</sup> / <sub>2</sub>
80	80	3
100	100	4
125	125	5
150	150	6
200	200	8
250	250	10
300	300	12
350	350	14
400	400	16
450	450	18
500	500	20

4	Description		
Body Code	JIS	ASTM	
31	SCS13A (304)	CF8 (304)	
32	SCS14A (316)	CF8M (316)	
62	SCPH2 or S25C	WCB	

5	Ball	Seat	Packing	Stem
Trim Code				
3L	St.St. with HCr	St.St. (Laminate)	PTFE	St.ST.
3S	St.St. with Stellite	St.St. Stellite	PTFE	St.ST.

St.St. Stainless Steel  
HCr. Hard Chromium Plating

9	Description
Option Code	
Blank	No additional option